

V8

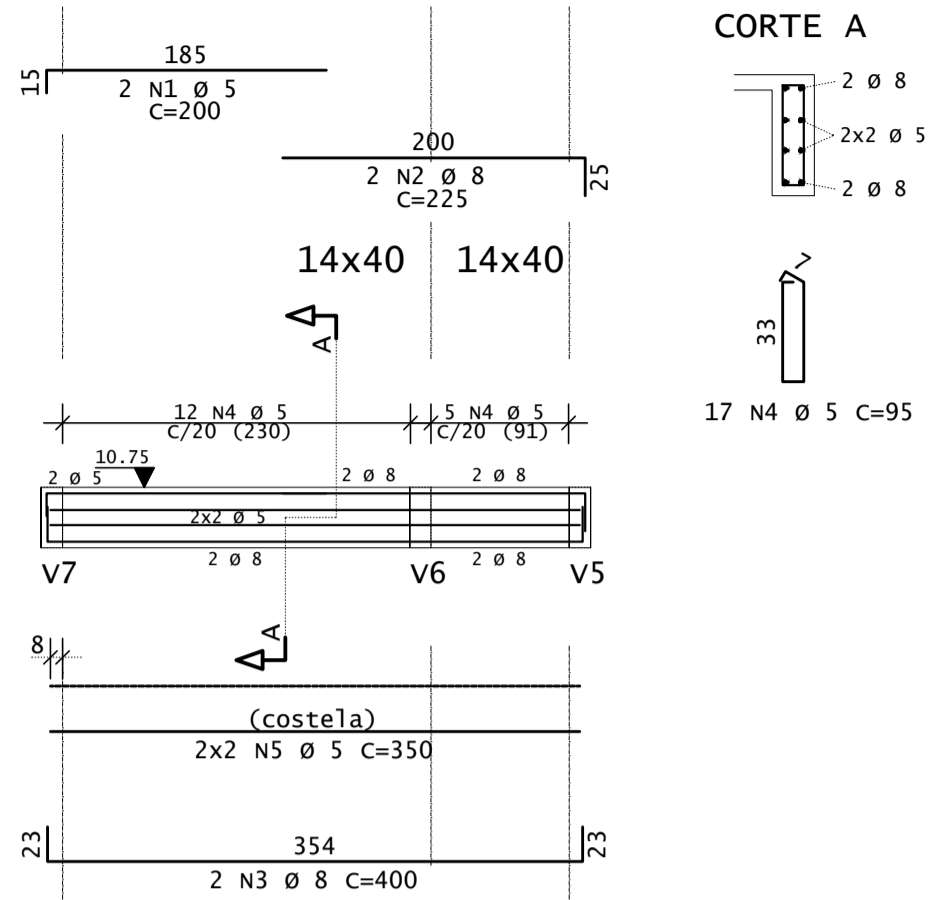

V9

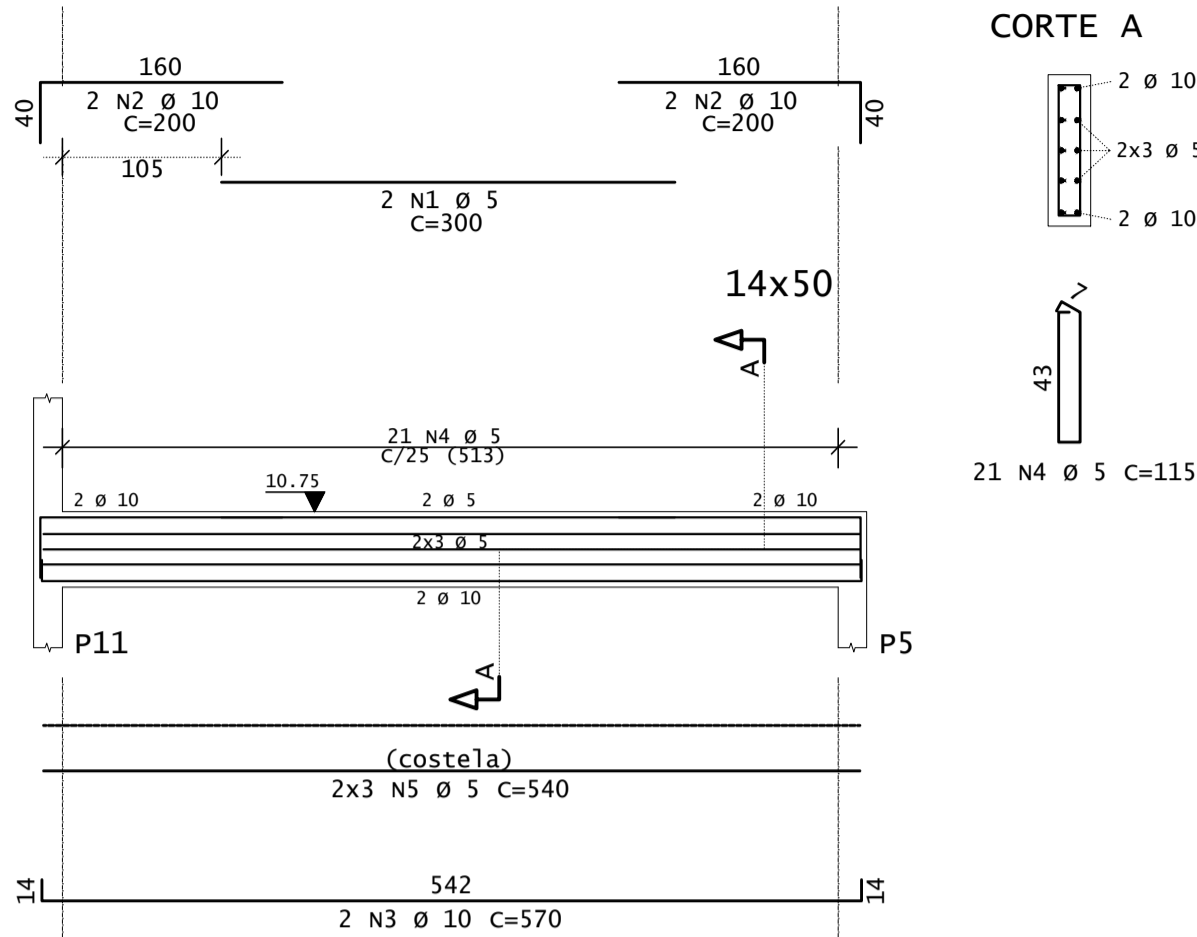

V10=V14

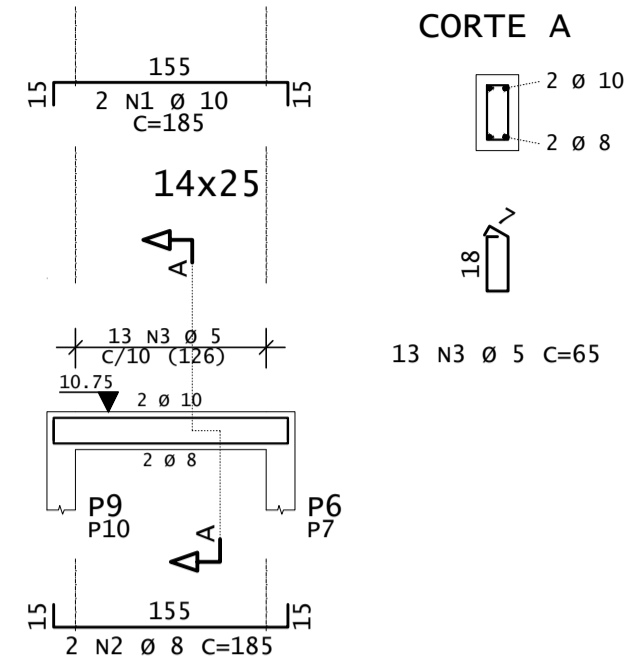

V11

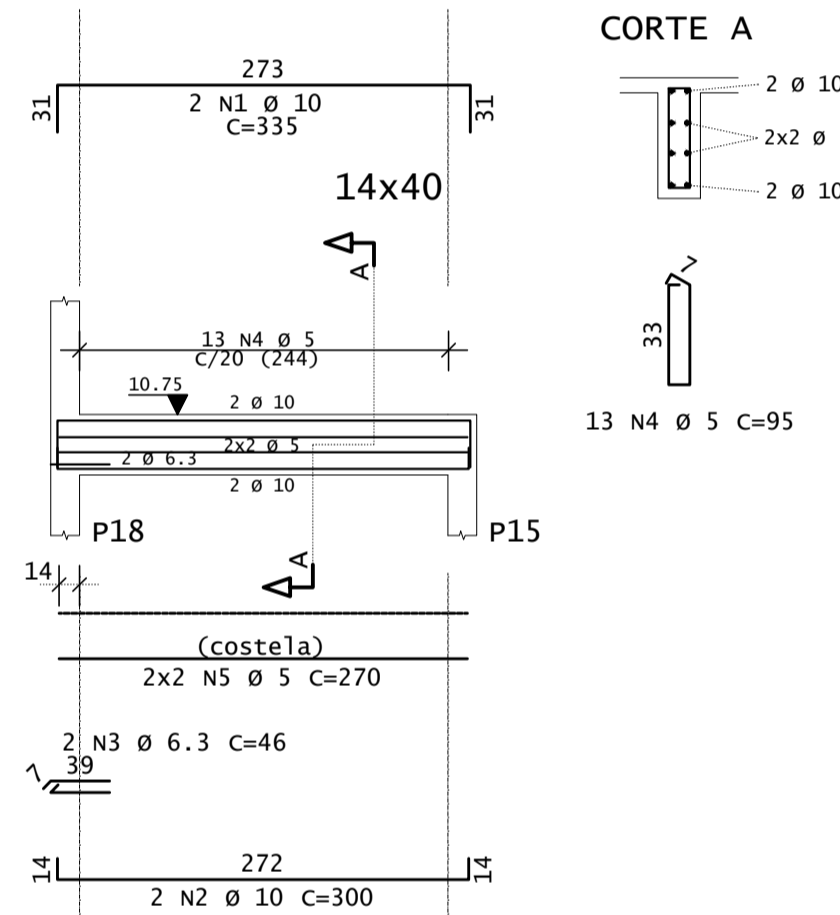

V12

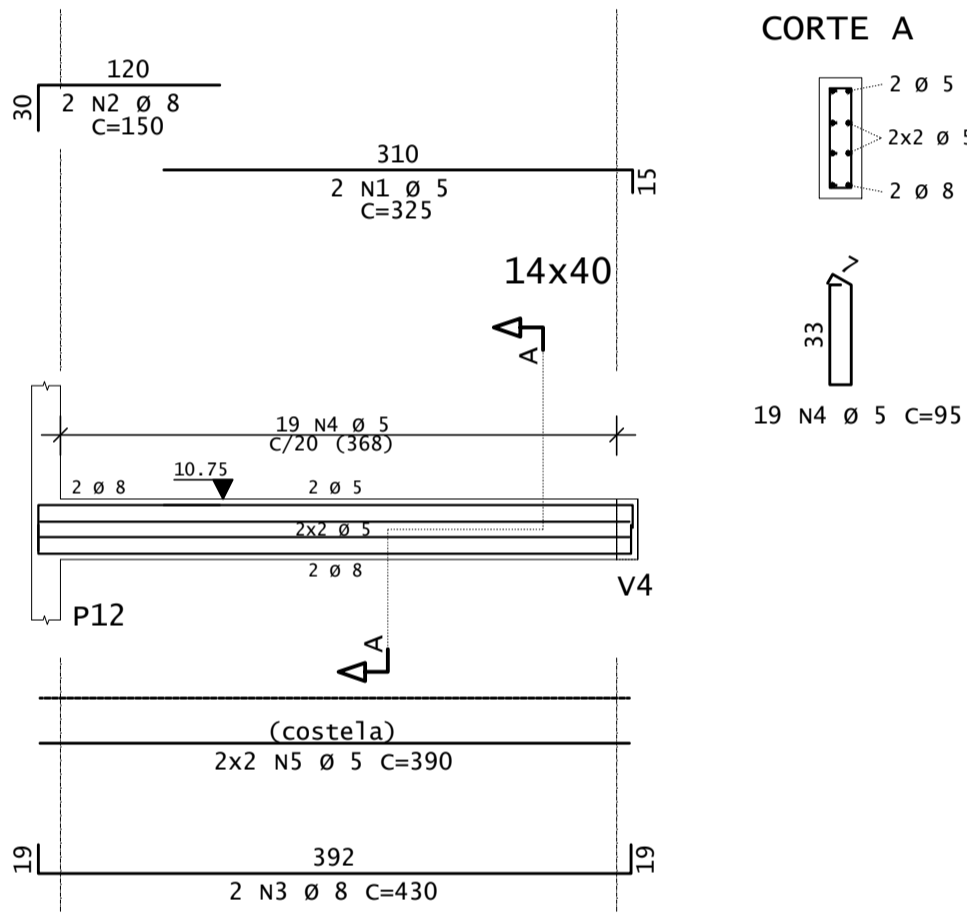

V13

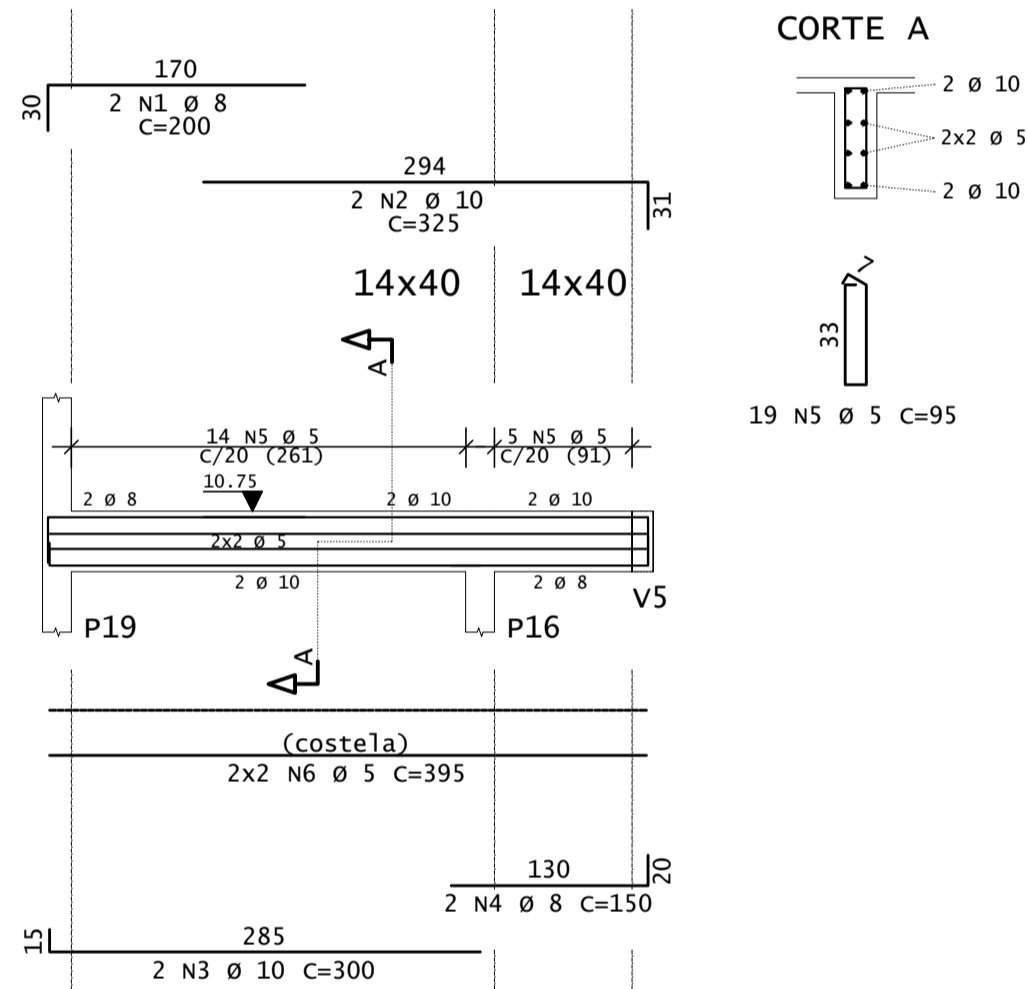

V15=V17

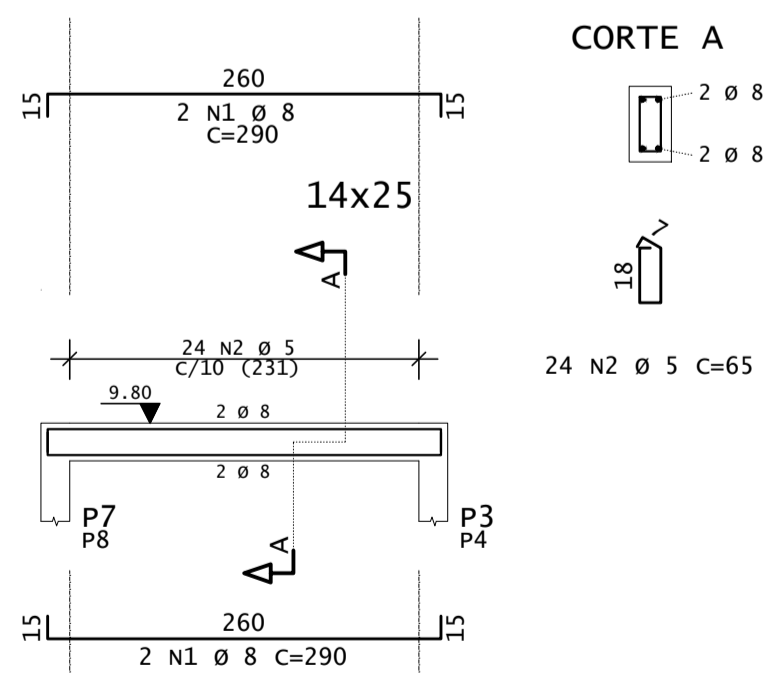

V16

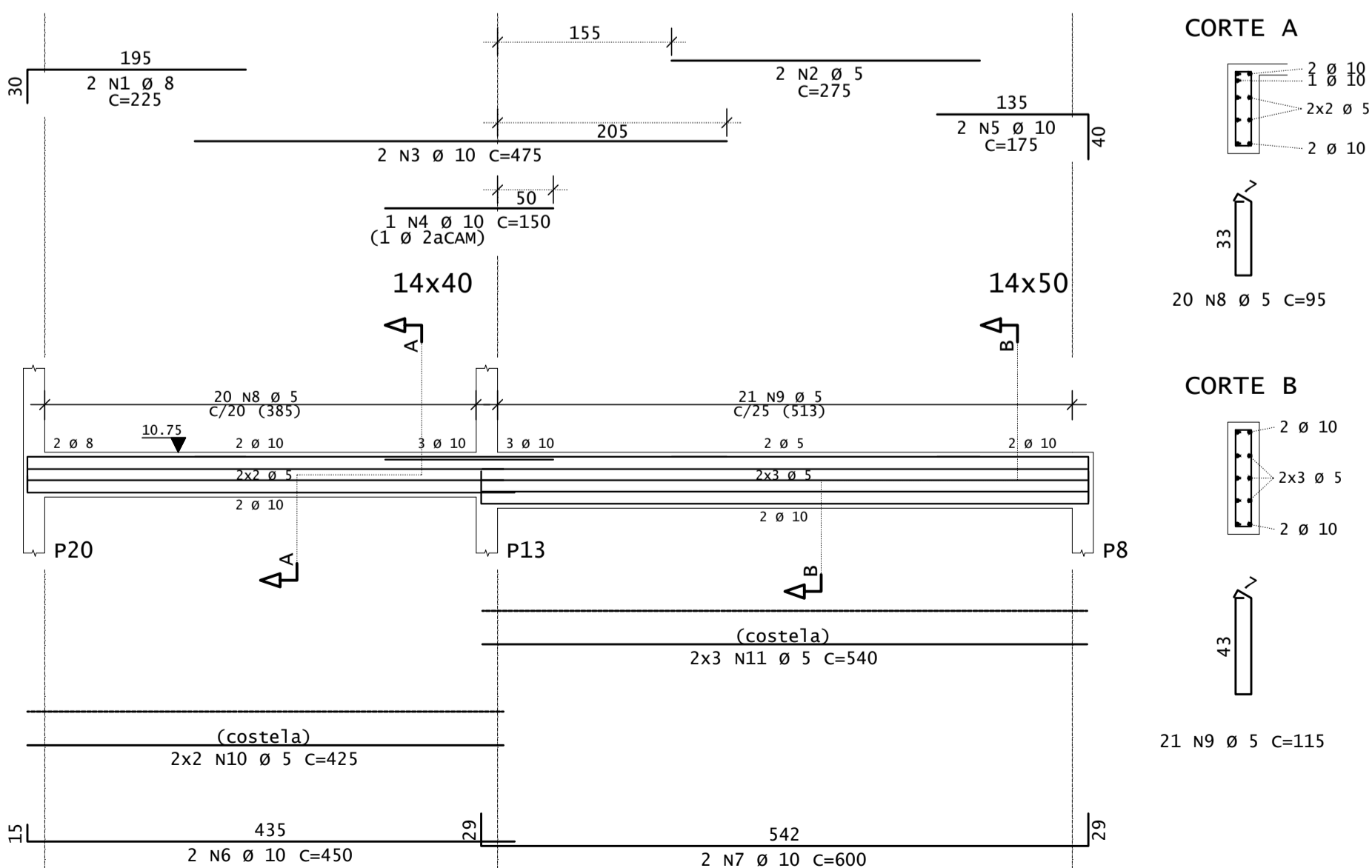

DIÂMETROS DE CURVATURA

Ø	8	10	12.5	16	20	22.5	25
db	4	5	6.5	8	16	18	20

AÇO	POS	BIT	QUANT	COMPRIMENTO	
				UNIT	TOTAL
		mm		cm	cm
V8	60	1	5	200	400
	50	2	8	225	450
	50	3	8	400	800
	60	4	5	95	1615
	60	5	4	350	1400
V9	60	1	5	300	600
	50	2	10	4	200
	50	3	10	2	570
	60	4	5	21	115
	60	5	6	540	3240
V10=V14	(X2)				
	50	1	10	4	185
	50	2	8	4	185
	60	3	5	26	65
V11	50	1	10	2	335
	50	2	8	2	600
	50	3	6.3	2	46
	60	4	5	13	95
	60	5	5	4	270
V12	60	1	5	2	325
	50	2	8	2	150
	50	3	8	2	430
	60	4	5	19	95
	60	5	5	4	390
V13	50	1	8	2	200
	50	2	10	2	325
	50	3	10	2	300
	50	4	8	2	150
	60	5	5	19	95
	60	6	5	4	395
V15=V17	(X2)				
	50	1	8	8	290
	60	2	5	48	65
V16	50	1	8	2	225
	60	2	5	2	550
	50	3	10	2	475
	50	4	10	1	150
	50	5	10	2	175
	50	6	10	2	450
	50	7	10	2	600
	60	8	5	20	95
	60	9	5	21	115
	60	10	5	4	425
	60	11	5	6	540

RESUMO DE AÇO				
AÇO	BIT	COMPR	PESO	
		mm	m	kgf
60	5	340		52
50	6.3	1		0
50	8	66		26
50	10	88		54
Peso Total			60	52 kgf
Peso Total			50	80 kgf

REV	DATA	DESCRIÇÃO
00	14/07/2022	MONTAGEM INICIAL

ASSINATURAS E APROVAÇÃO

PROJETISTA: LEONARDO SEVEIRA LIMA  
ENGENHEIRO CIVIL - RNP: 091551067

PROPRIETÁRIO: PREFEITURA MUNICIPAL DE ARACATI

PROJETO: CONSTRUÇÃO DE BANHEIRO PÚBLICO E PRAÇA DE MAJORLÂNDIA

CONTENIDO: PROJETO DE ESTRUTURAS EM CONCRETO

ARMADURA DAS VIGAS - PARTE B

IDENTIFICAÇÃO DOS DESENHOS: 01 - COBERTA - VIGAS V8 A V17

LOCAL: MARJORLÂNDIA - ARACATI

DATA: JULHO/2022

PROJETADE: JMYM/SCS

ESCALA: 1:50 - 1:25

CONTROLE: C.22.25

PÁGINA: 12/13