

V1**V2****V3****V4****V5****V6****V7****V8****V9****V10**

AÇO	POS	BIT (mm)	QUANT	COMPRIMENTO	
				UNIT (cm)	TOTAL (cm)
V1					
60	1	5	2	350	700
50	2	10	2	207	414
50	3	12.5	2	225	450
50	4	16	2	660	1320
50	5	6.3	4	46	184
60	6	5	24	135	3240
50	7	8	4	628	2512
V2					
60	1	5	2	300	600
50	2	10	4	200	800
50	3	12.5	2	600	1200
50	4	6.3	2	46	92
60	5	5	22	135	2970
50	6	8	4	580	2320
V3					
60	1	5	2	350	700
50	2	10	2	225	450
50	3	12.5	2	675	1350
60	4	5	25	135	3375
50	5	8	4	651	2604
V4					
60	1	5	2	300	300
50	2	8	2	145	290
60	3	5	11	65	715
V5					
60	1	5	2	175	350
50	2	8	2	170	340
60	3	5	13	65	845
V6					
60	1	5	2	275	550
50	2	8	2	160	320
50	3	12.5	2	350	700
50	4	6.3	8	41	328
60	5	5	20	75	1500
V7					
50	1	6.3	2	300	600
50	2	12.5	2	250	500
50	3	8	2	475	950
60	4	5	27	75	2025
V8					
50	1	12.5	2	250	500
50	2	8	2	375	750
50	3	10	2	425	850
50	4	10	1	200	200
50	5	8	2	910	1820
60	6	5	42	95	3990
60	7	5	4	425	1700
60	8	5	4	475	1900
V9					
50	1	10	4	350	1400
60	2	5	20	75	1500
V10					
60	1	5	2	250	500
50	2	8	2	150	300
50	3	8	2	360	720
60	4	5	15	95	1425
60	5	5	4	315	1260

RESUMO DE AÇO			
AÇO	BIT (mm)	COMPR (m)	PESO (kg)
60	5	301	46
50	6.3	12	3
50	8	128	51
50	10	46	28
50	12.5	47	45
50	16	13	21
ØØse Total			46 kg
ØØse Total			148 kg

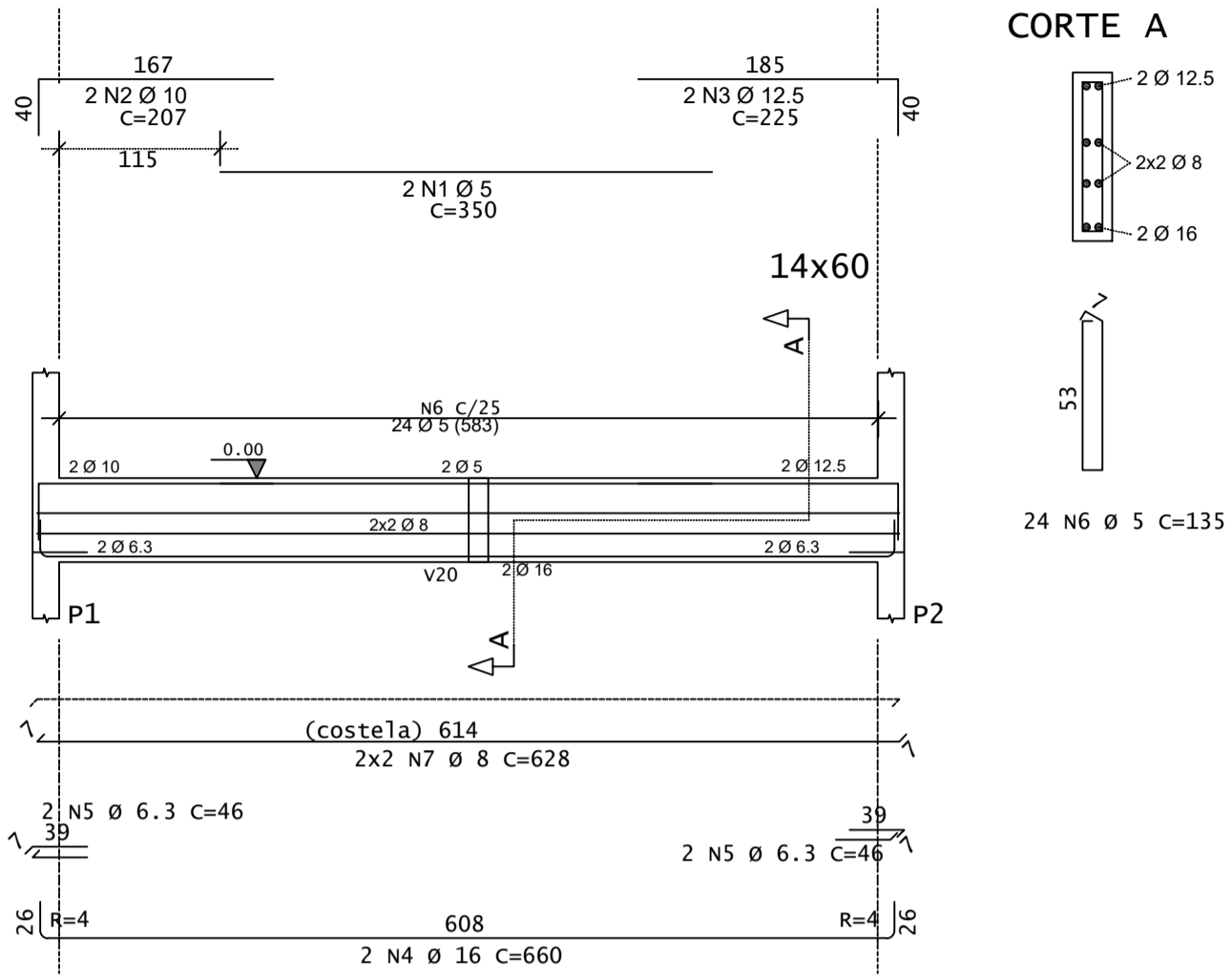
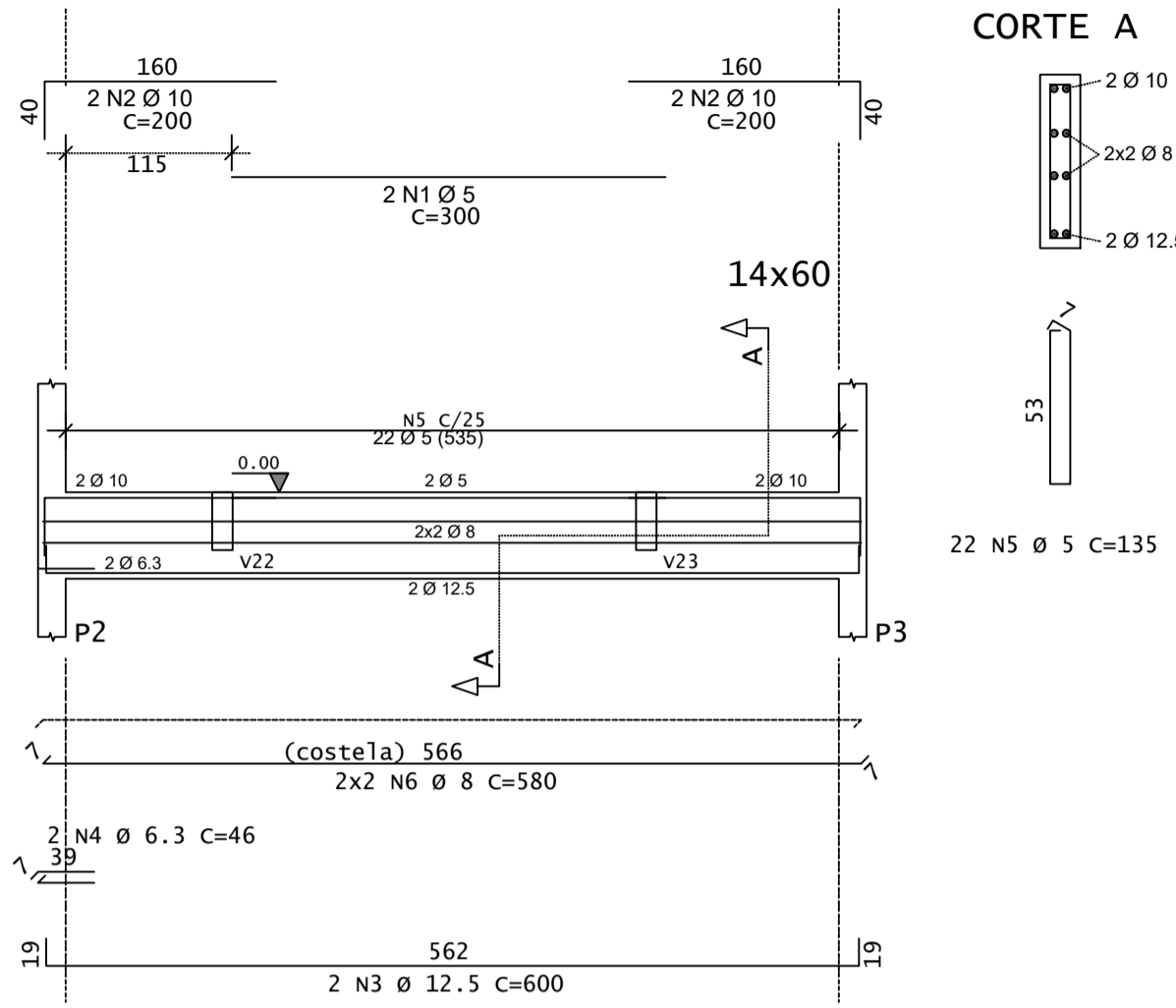
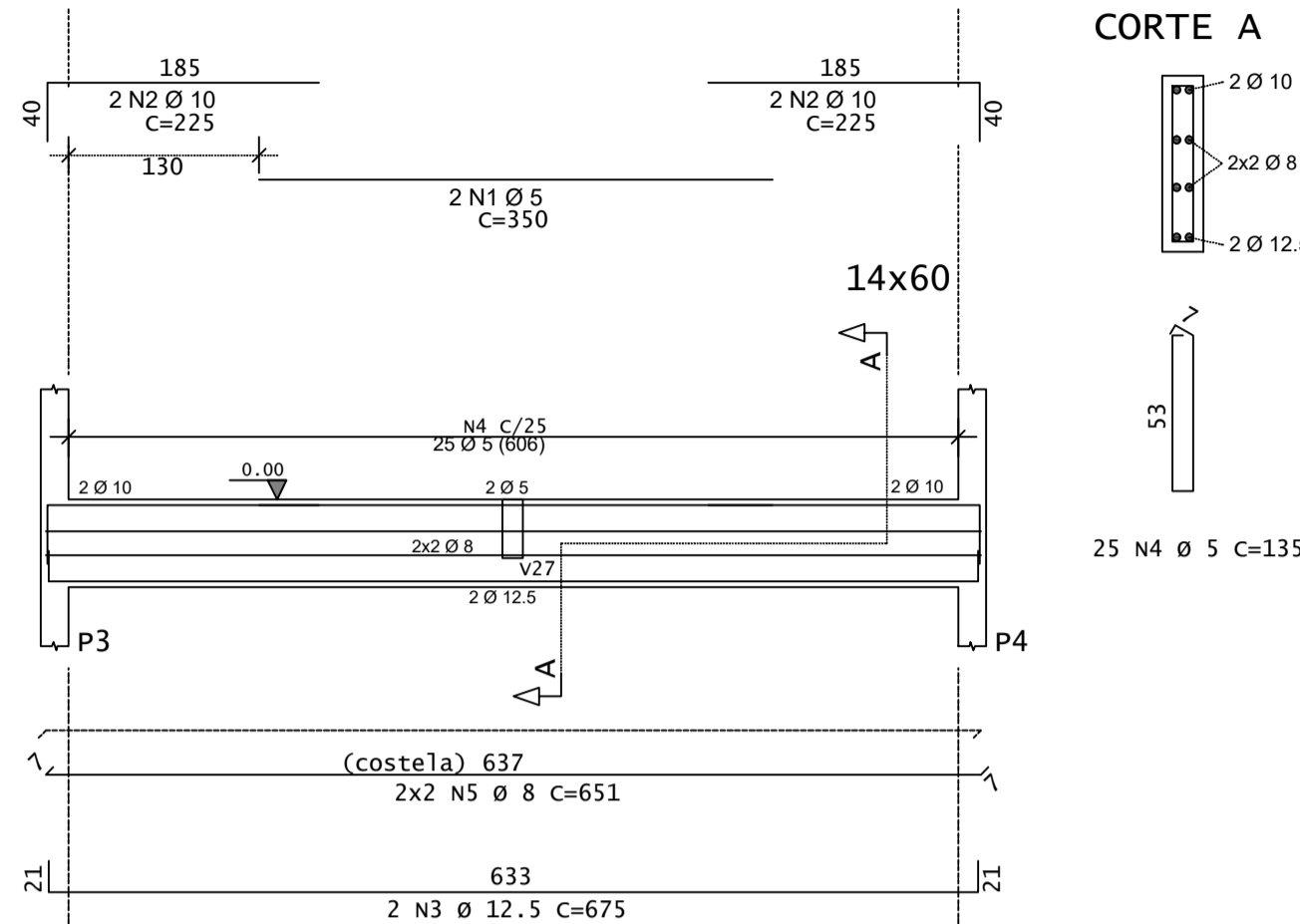
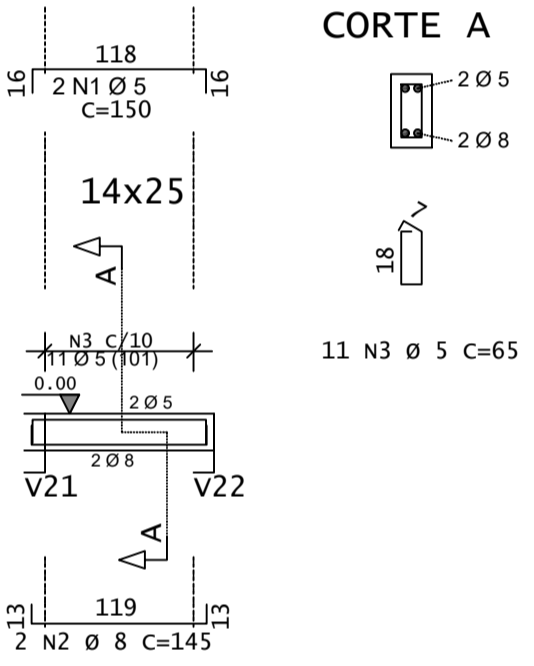
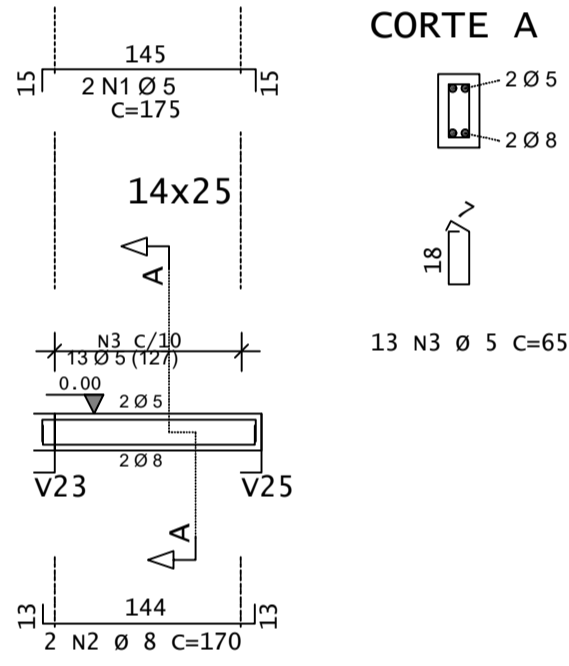
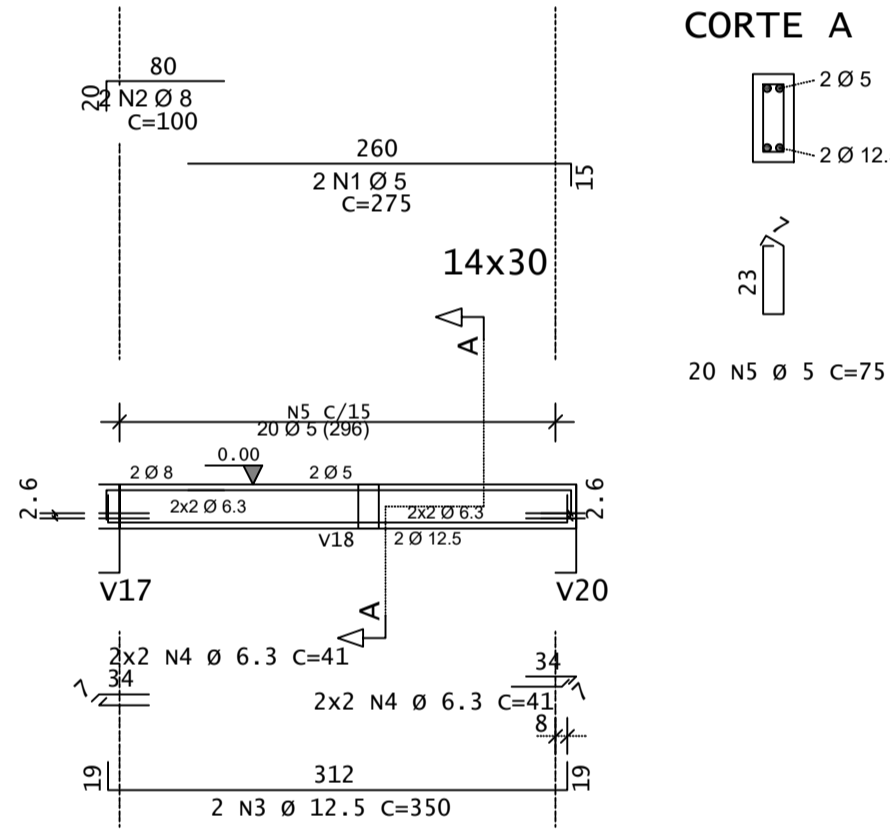
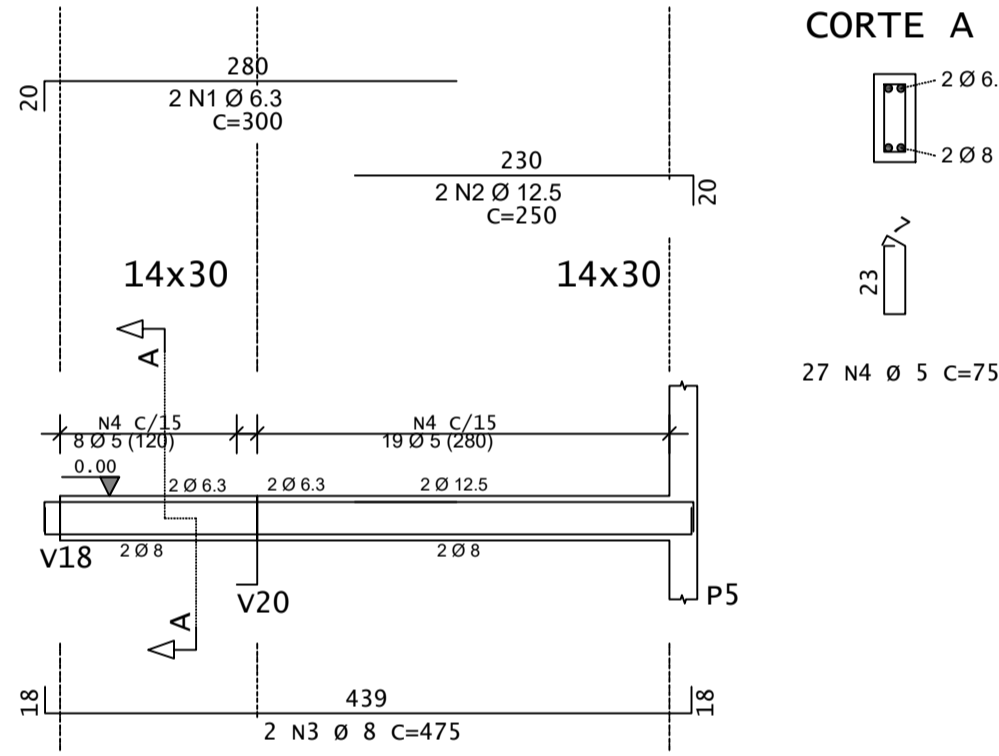
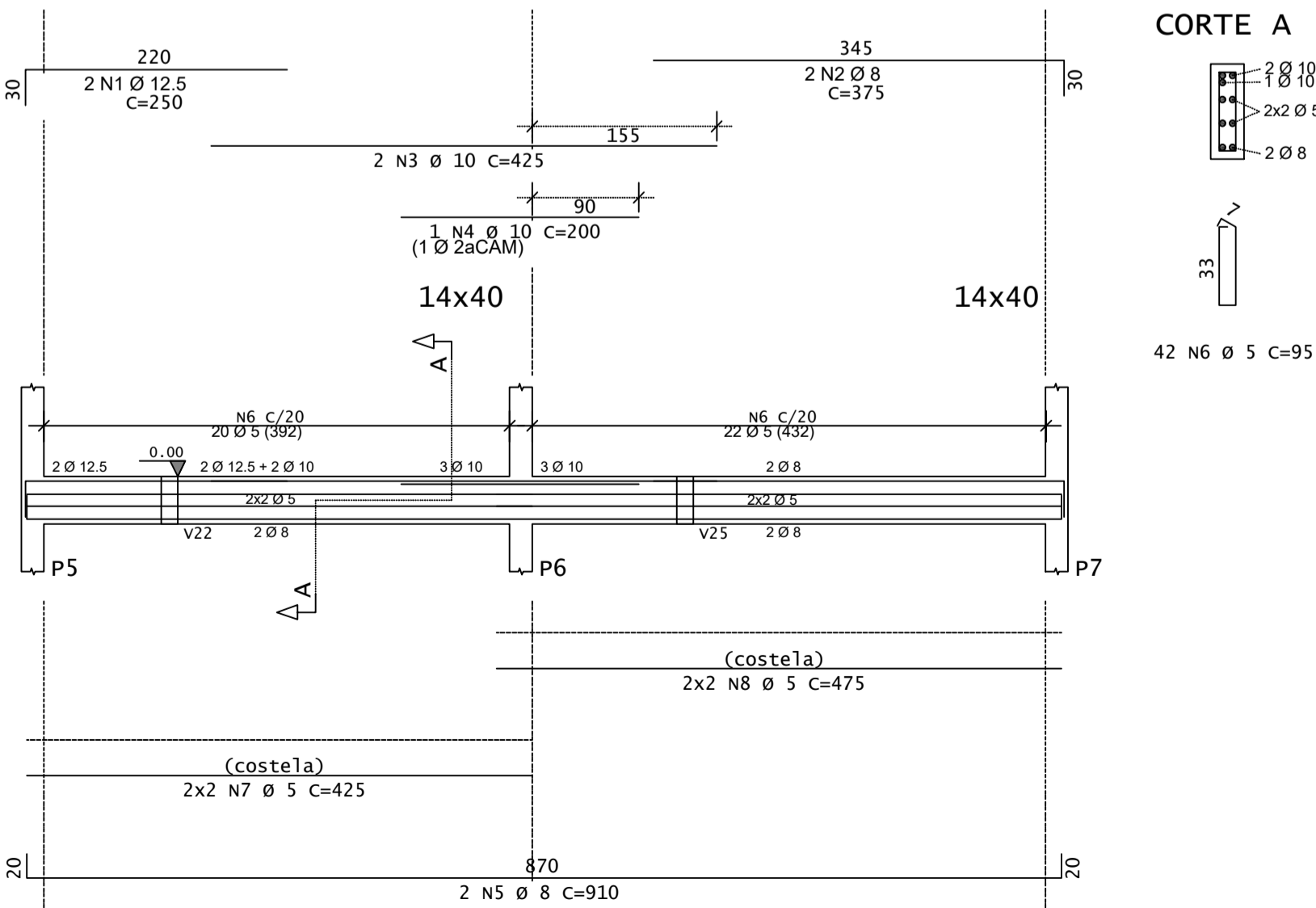
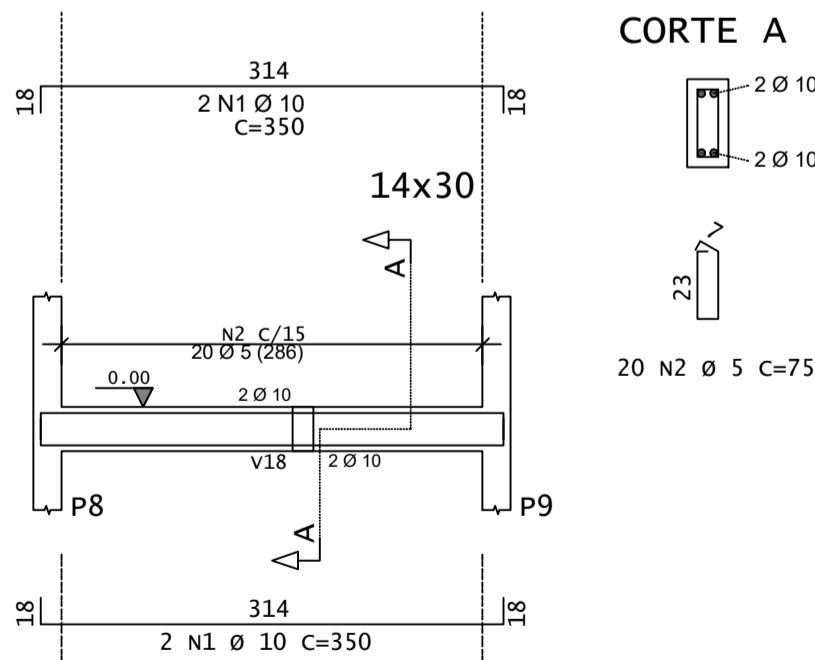
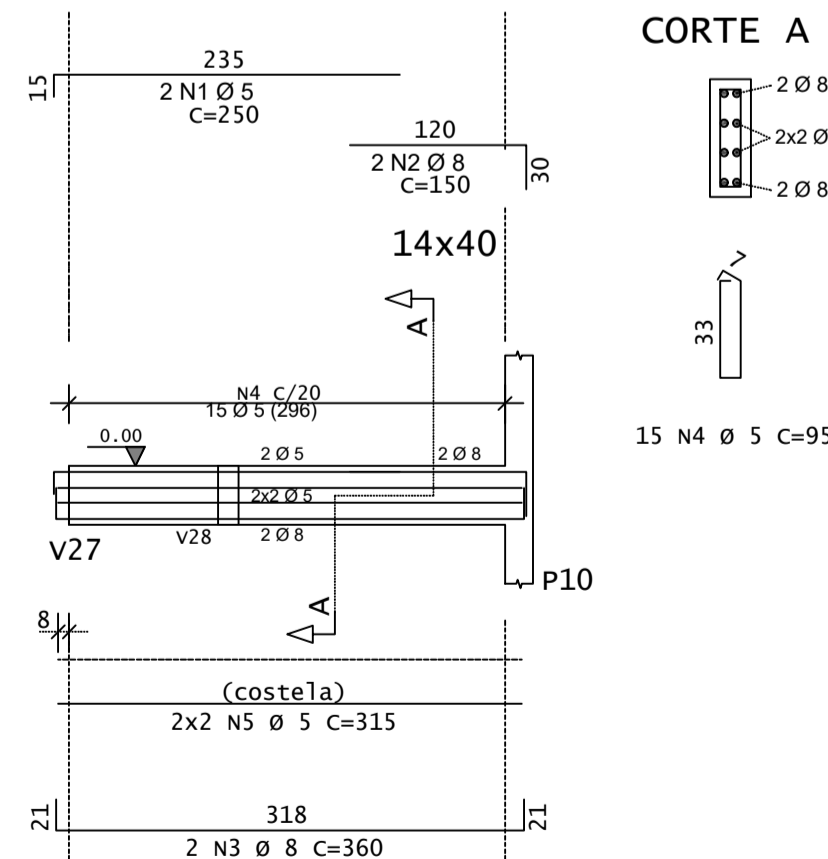

PROPRIETÁRIO:
PREFEITURA MUNICIPAL DE ARACATI

OBJETO:
CONSTRUÇÃO DE UM POSTO DE SAÚDE NO BAIRRO FARIAS BRITO

PROJETO:
PROJETO DE ESTRUTURAS EM CONCRETO

CONTEÚDO:
VIGAS

IDENTIFICAÇÃO DOS DESENHOS:
01 TERRECO - VIGAS
VIGAS - V1 A V10

RESPONSÁVEL TÉCNICO:
FILIPE DE OLIVEIRA DO AMOR DIVINO | CREA 061564432-5

LOCAL:
RUA MARIA ISaura, BAIRRO FARIAS BRITO, ARACATI-CE

DATA:
ABRIL/2024

PROJETA:
DESSENHO:
05/13